

Volume 35
Issue 1
Jan-Feb
2011



REPLICA

Newsletter of the National Association of Scale Aeromodelers [NASA]

FLASH NEWS from the
National Air-Model Meet



2011-2012 Rules are published on the AMA web site:

www.modelaircraft.org/events/compreg.aspx

The National contest scale events were set December 1st. AMA events this year include:

New being offered:
527 CL Team Scale

Not being offered this year:

524 CL Designer Scale
F4B FAI CL Scale

2012 F4C FAI RC Scale trials will be at the Nationals this summer with 3 contestants and one alternate cho-

Toledo 2006 >

Scale Contests-Events

NATS

June 25, 26, 27, 28, 29
Johnson City, TN
FF Indoors
6 FAC events

July 1, 2, 3 Muncie, IN
CL 509,510 (F4B), 521,
526, 527

RC Fixed Wing 511,
512,515,516 (F4C),520
(Novice and Open), 522

July Muncie, IN
RC Sailplane None

July 18, 19, 20, 21, 22
Muncie IN
FF Outdoors 18-22
9 FAC Events

August 7, 8, 9, 10, 11
Muncie, IN
RC Helicopter —518



NASA Officers 2010-11

President

Mike Barbee mabarbee@aol.com
Delaware, OH 740-362-5504

Vice President

Steve Ort stoandsto@aol.com
Seymore, IN 812-524-9703

Sec / Treasurer

Bob Lirette blirette@sbcglobal.net
Menomonee Falls, WI 262-251-0804

NASA Communications

Replica Editor – Publisher
Ted Kraver ted@kraver.cc
225 West Orchid Lane
Phoenix, AZ 85021
602-944-8557

Web Master — Mark Lanterman
mark@airbornemedia.com.
888-829-4060

Past Presidents

Stan Alexander
onawing4602@att.net
Ed Terry
cptforensics@juno.com

In This Issue:

- 2 President's Message;
2. Editor's Thoughts
3. 12 Inches to the Foot
3. Art Chester's Goon
4. Bob Underwood—Founder
4. 1977 Riverside Nationals
5. San Diego Museum & Modelers
- 6.-7. Toledo Show 2011
8. About NASA -Renewal Policy



President's Message Mike Barbee

You can email me at:
Mabarbee@aol.com

Hello everyone, well the first major contest of the season is about to start. I really enjoy Top Gun probably because I lived through one of the toughest Ohio winters I can remember. There are a number of good contests in a five state area around Ohio. The NASA banner will be traveling with me to at least five contests this season. Please don't forget to renew your dues NASA depends on your support.

The AMA is planning on a big celebration this year in Muncie at the National Flying Site. The start of the activities will be the Scale Nat's July 1,2,3, please try to attend and support your special-intrest group NASA. Picnic at the field is planned for Saturday after flying.

This year the Toledo Show was well attended and I had an opportunity to meet many old members and collect their dues. There were many nice scale models on display. Most were very large in the 50% category. I conducted my Building Scale Seminar on Friday and Saturday. It was well attended with 58 scale modelers in my Saturday session. I gear it more for the beginners because all you old guys know everything already. Next year with help from John Boyko we are going to cover building and then flying the second hour. Hope to see you there plan a head.

If you attend any of the contests in the Ohio area look me up I will be happy to help you.

Send in your dues, see you at the flying field.

Mike Barbee

Editor's Thoughts

Ted Kraver

I have a life that depends on luck. I might like to switch over to blessings but I am saving those points



when I will need them far in the future. My luck includes having a marvelous time with my boyhood passion for model airplanes (pre girls). My converted wood-shed=>work shop with flying field 100 yards behind on our small Ohio farm was utopia. Twenty-five years later I was at my first Nationals—Riverside 1977, see top of page 4.

Last week I was at a meeting in DC where, as an ice-breaker we were asked who would be if we could do anything we wanted to do. I answered, "**A model airplane enthusiast, designing, building and flying as a flower child of 40 years ago.**" (check top of page 4 again.)

Decade after decade I had made numerous attempts, all fun, all failures in sustained achievement. So on February 28th I told my sister (the smart one) that I was immediately ending my two decades of civic entrepreneurial advocacy to transform K12 education. I had decided to declare victory and disappear into my work shop. But I made a big mistake. I had decided to attend two massive ed-tech leadership meetings, one in AZ and one in DC in early April.

At our eLearning task force meeting last Friday our leader, my wife Bobbie, announced that I was committing to another year, maybe two to the cause. Having to make a decision between designing, building and flying or continuing editing three of out hobby/sport newsletters I went out to my shop to think. A half hour later I had cleaned off my bench, and stored a half dozen new projects and repair jobs and went back to my computer.

I intend to have a great time crafting these pages and keep in touch with all of you, and hopefully do some good for our next generation. The planes will be there when I return in a couple of years.

This week I am off to a week in Orlando, and hopefully see a shuttle launch. Like big game hunting, you have to depend on the buck to show up. My model buddy from the 1970's Pete Mazur and I expect to take in the Navy and Army air museums in the Florida panhandle and south Arkansas. Lots of newsletter photos.

Cheers, Ted

12 Inches to the Foot—Stan Alexander

Wow, lots happening this year at the **National Aeromodelling Headquarters** in Muncie. This is the **75th year for the National Championships**. Scale has long been a part of the Nationals and we have been fortunate thanks to people with vision to have the site we currently have at Muncie. Is it perfect? No. But then what is? Haven't been to perfect yet, but when I do you'll be the first to know.

This is also the time for the team selection **for Team USA for F4C scale**. F4B has been deleted as a world championships event by the CIAM along with several other events. But the team selection goes on as an un-funded portion of AMA's FAI program. Hope I got that right..... for more information check out the NASA website at **www.nasascale.org** or contact FAI Team Selection Committee Chairman Jack Buckley at **JCMBUCK@verizon.net**

F4B is still a international event that can be held anywhere in the world, even here in the USA and it's still in the FAI Sporting Code for that reason.

F4C or RC Scale will be held in Spain in 2012, with a beautiful flying site within the northern part of the country. For more information on the site, the surrounding area as well as upcoming events check out their website, available in English at **http://scale-wc2012.es**

Also note that the Spanish also plan to hold the equivalent of AMA Sport Scale or as we call it F4H as well as F4G (large Scale) at the championships. These are not world championship events, thus there is no team selection here in the USA.

This is also the **100th Anniversary of U.S. Naval Aviation** and this will be celebrated across the country all year I'm sure. It would be a great time to go to the museum in Pensacola, FL. One of the country's very best aviation museums. If you go there before the Air Show season starts you might be lucky (Wednesdays) and see a great air show practice from the Blue Angels. Pensacola is their home base.



ART CHESTER 1936

The Art Chester Goon

Art Chester flew many different aircraft in the 1930s in air racing. He named his aircraft after cartoon characters from the Popeye comics of the day. Art spent most of his time and money on making the Goon good fast and turn left. Thus it had a very plain paint scheme of Cream, probably the same paint as used on his Jeep. (The same familiar cream color as was used on the "Jeep" was used on the "Goon" and the race number 5 was added for the Nationals. Ted the eD)

He won the **1939 Greve Trophy** in the Goon and continued to work on the airframe and engine making it faster in the process. The Goon is powered by a C6S-4 Menasco engine and this is one of the only surviving race winners that still exists today, although without it's engine.

The Goon is in storage, awaiting restoration at the **Western Reserve Museum** in Cleveland, Ohio still today. It has been in storage (the last time) since 1991, wow that makes another 20 years the plane has been stored. Hope it receives some attention soon!

If you know where there are any large scale plans of the Goon please let us know. The airplane if you aren't familiar with it, is actually longer than it's wingspan. It has retracts something like an F-16, but with a twist. It also has a retracting tail skid.

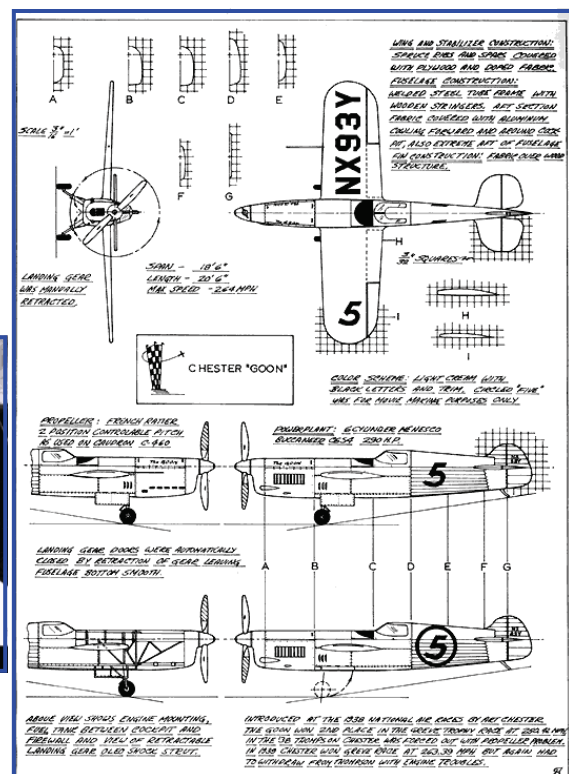

Bob Underwood — NASA Founder

Throughout 1976 I corresponded with some 100 scale modelers in the United States by providing a very simple newsletter and by compiling information regarding their individual interest in forming an AMA SIG for scale. With the encouragement received, I arranged with John Worth to hold an organizational meeting during the 1977 NATS which was held at March Air Force base in Riverside, California. About 75 individuals attended the meeting and resulted in the formation of the National Association of Scale Aeromodelers (NASA).

The vision developed that day was not only to promote scale modeling, but to represent the activities found in the three modeling disciplines; that is, Free Flight, Control Line and Radio Control. To that end, we created three Vice President positions with each to represent one of the three categories. In addition, a Secretary/Treasure position was created and dues set. I was elected President.

Several goals were considered at that time. A newsletter was established, in addition to a means of providing a Scale Source Guide to aid in documentation. Consideration was given to the establishment of a rule review committee to advise the Contest Boards in the development of what was then known as the "Rule Book" (present Competition Regulations).

Assistance was pledged in providing guidance relating to judging at major events, including the NATS, as well as providing forums concerning the training of judges to distinguish between the type of scoring which differentiates so-called "pattern" and scale flying. Lastly, help was pledged to attempt to foster greater interest in international events (FAI), as well as provide personnel to assist with any prospective World Championships and guidance for the United States Subcommittee member on the CIAM. There was no specific "Mission Statement" formulated at the time, primarily because the term was not really in vogue then. Cheers Bob Underwood

Riverside AMA Nationals

The Riverside NATS also saw the formation of the CL Stunt SIG PAMPA and the CL Navy Carrier Society SIG with Keith Trostle and myself being the respective meeting conveners. Also my first NATS and first look at national class scale. I remember taking an 8mm film of an RC scale plane that got into a spin, and never recovered. Ted the eD

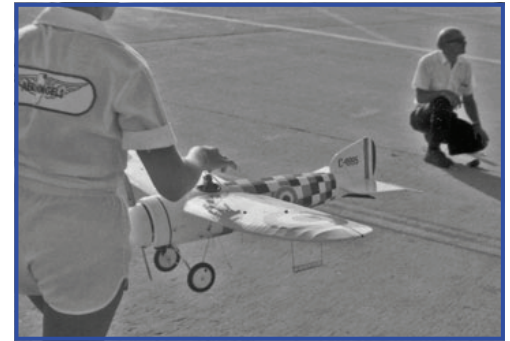

These B&W were taken at the 1977 NATS—scanned and photoshopped. The top photo has my 1970's flying buddy Jim Storts, son Chuck, and myself with The Camping Trailer.

Hundreds of photos, and then somehow you hit the good one. Take some time to check the composition, scene and hands at the right.



Igor Sikorsky Pioneer Designer



Chuck Yeager and the Bell X-1

San Diego Air museum engages scale modelers. Some of us dabble in oils and dioramas, and some like me are lazy and like only building the right wings on a biplane. They are looking for a P-38.



Naval Aviation 1930's



SAN DIEGO AIR MUSEUM

Toledo Show April 2011

NASA Booth Miesters
Dale Arvin

Mike Barbee

Bob Lirrette
 (center)



Best Of Show

M25 40 Ton Transporter
 Chris Weiss Painesville, OH



OK guys, challenge for next year!
 Are you going to let an olive drab tractor with a tank on it beat out a magnificent airplane next year?

Tom Poole catches a break in the booth, after a long haul through the booths. Looks like the bag is full of great stuff. Now he just has to get it to the workshop and start building .



John Boyko's Cessna Sky Ranch with 120" wing span when he gets the wings on.



Mike Barbee's T34 at 33% scale. Much fiberglass through out.

Check out the great new banner. Great colors and design.



Designer Scale Airplanes



1st Piper Super Cub PA-18 Graeme Mears Woodbridge, Ontario, CA



2nd Fokker Eindecker Bill Setzler Millersville, Md



3rd Junker Ju52-3mJg7e Jim Beavers Dearborn Hgts, Mi



Best Finish Paint
3w Ultimate 44%
John Deyoung
Dewitt, MI



Sport Scale

1st Piper Supercub PA-18 Graeme Mears, Woodbridge, Ontario, CA

2nd Fokker Eindecker Bill Setzler Millersville, MD

3rd Junker JU52-3MIG7e Jim Beavers Dearborn Hgts, MI



Military Sport Scale Plane

1st SNJ-5 Frank Shirley Columbus, OH

2nd Meister P-47 D Gary Prince North Canton, Oh

3rd Nieuport 17 1/3 Scale Steve Eagle Wabash, IN



Jet Scale Plane

1st BAE Hawk Mk66 Blair Howkins Caledon, Ontario, Canada

2nd F-18F Curtis Wade Detroit, MI

3rd Jet Legend F-16 Chris Tucker Redford, MI



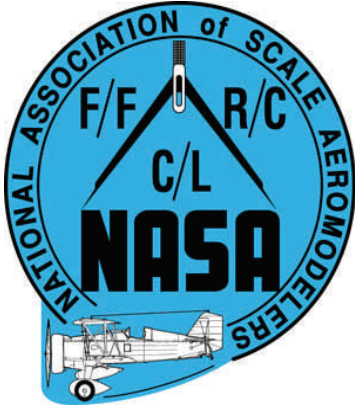

Join or renew NASA for 2011 today! Complete the following application (please print) and mail it to:

Bob Lirette, Secretary/Treasurer NASA
W162 N9440 Blackfoot Dr.
Menomonee Falls, WI 53051

Membership dues are \$20.00 yearly (newsletters sent to foreign members sent by e-mail), or \$25.00 (foreign with newsletters set by post.)

Make checks or money orders payable to: National Association of Scale Aeromodelers.

NASA Newsletter advertising. The following rates are for full color or B&W :

1 issue and 6

issues:

Full page	\$65	\$270
1/2 page	\$45	\$180
1/4 page	\$30	\$150
1/6 page	\$25	\$120
1/10 page	\$15	\$70

Member "want ads" of limited length - one time at no cost.

NASA is the **AMA Scale Special Interest Group** or (SIG) for the USA. We encourage Scale Contests, Scale Fly-Ins and work to promote and advance all phases of scale aeromodeling. Whatever your interest is, RC, CL or FF Scale, NASA has something for you! NASA is the official host of the **AMA Scale National Championships**, held in Muncie, IN. Held at the AMA Flying Site, we offer classes for RC, CL and FF scale competition. Interested in competing or judging? Contact a NASA officer or the Event Directors. Hope to see you there! If your interest doesn't include competition, fear not! NASA membership is still a treasure chest for any scale modeler or documentation scholar. Our **Scale Resource Guide** can provide you with many organizations, both government and private as sources of documentation and information. This **Newsletter** is published 6 times per year. New sources of documentation, building tips, contests updates, Scale News, FAI Scale information, 3-views are all available here for our membership.

NASA **Website** <http://www.nasascale.org> is a great source of information about upcoming events, documentation, museums, photos, contest results, a help section for scale modelers as well as down loadable score sheets for all AMA scale classes. NASA **Flight Achievement Award** is presented at NASA sponsored scale contests or fly-ins. This award is decided upon by a vote of the contest flight judges, by which subject best duplicates prototypical flight, taking into consideration the uniqueness of the subject and flight characteristics. For more information contact a NASA officer.

NASA MEMBERSHIP RENEWAL DATA CHANGE



Several years ago NASA slipped from an Annual Renewal Date to everyone having a personalize renewal data. As a thinly staffed volunteer organization we are going back to a December 31st renewal date. If in 2010 you joined prior to the AMA Nationals you



need to renew now for 2011, of you have not already done so. If you joined at the 2010 AMA Nationals or later, then you are covered through 2011. This allows us to do a big membership renewal push in the last quarter of the year. It allows you to mark the year-end in date in your calendar to remind yourself to renew. This lets you get you renewals done in one fell swoop.

Name: _____ New Renewal Address Change

Address: _____ AMA # _____ NASA # _____

City: _____ Tel: _____ - _____ - _____ E-mail: _____

State: _____ Zip: _____ Country: _____

Area of Interest: Free Flight Indoor Control Line Radio Control Giant Sailplane Electric

CHECK HERE if you do NOT want your name and address included in a directory to be distributed to NASA members. NASA will not sell this directory to anyone.