

REPLICA

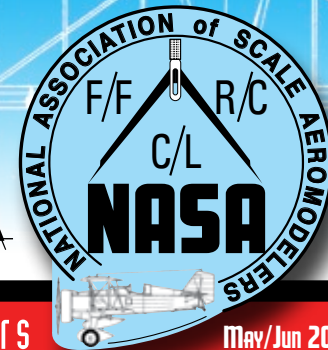

Newsletter of the National Association of Scale Aeromodelers

May/June 2013

NASA Airplane Raffle - Time's Running Out!!!!



To raise funds to help with the expense of the Scale Nats operations, in last year's board meeting at the Nats, the board approved the motion to have an airplane raffle this year.

Horizon Hobbies donated an 88" Tiger Moth ARF, I donated a DLE-20 gas engine and Dick Petit donated his time (& digital JR servos) to assemble the airplane for us. Barbee Concrete donated the tickets.

Dick was also instrumental in getting several other companies to donate items needed to complete the process. The aircraft is ready to fly, all except a receiver (Dick kept his receiver). Just add your receiver of choice.

The engine has been test run and adjusted. The aircraft is eligible to enter in fun scale competitions with the appropriate photo and any giant scale fun-flies (IMAA).



Click here to buy your raffle tickets online!

Tickets are \$5.00 each, 3 for \$10.00 or 6 for \$20.00 and can be purchased from Mike Barbee, Mark Lanterman (thru the NASA website using PayPal) or Jim Martin. We can send any number of tickets to those willing to sell them. The drawing will be held Saturday night at the Scale Banquet at the Nats, July 13, 2013. We have acquired the Claude McCullough Education Facility building (by the AMA Museum) for the banquet again this year.

I hope everyone will help sell tickets and support NASA in our quest to make the Scale Nats better than ever.

JIM MARTIN
Jim.Martin@faa.gov

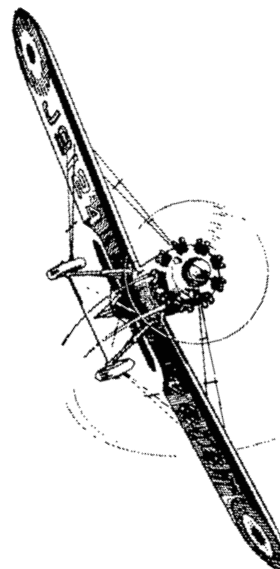

NASA OFFICERS

PRESIDENT

MIKE BARBEE

3903 Whispering Creek Lane
Delaware, Ohio 43015
740-362-5504
mabarbee@aol.com

VICE PRESIDENT

PAUL CAIN

1906 Center Street
New Albany, Indiana 47150
812-945-3103
c103iflyrc@att.net

SECRETARY/TREASURER

BOB LIRETTE

W162 N9440 Blackfoot Drive
Menomonee Falls, Wisconsin 53051
262-251-0804
robertlirette@gmail.com

REPLICA EDITOR/ NASA WEBMASTER

MARK LANTERMAN

7414 Burton Drive
Liberty Township, Ohio 45044
513-755-7494
mark@airbornemedia.com

President's Notes

Hi everyone, I know you have heard it before but, boy does the time fly when you're having fun. The 25th addition of Top Gun is now in the books and I am happy to say a different name was on top in the Expert division, me. After a minimum of test flights and inspection by Jim Martin for the AMA Large Model Wavier, I was in the zone while flying and managed four flights all above 92.75. The conditions this year were tolerable, not real hot, but a bit windy. Most directly down the runway didn't pose a problem to my 115 pound T-34 B. The expert category was well entered by a number of jets, but my good buddy Lee Rice managed to edge out a couple and finish third with his Corsair. With the lack of rules prohibiting a gyro most jet guys take advantage and use them, I wouldn't even know where to buy one then what to plug it in to. Enough for Top Gun - most magazines will cover the event in depth.

The real thing I want to write about this month is your support of the Nationals. We NASA need your help. The two best ways are renew or join NASA, then use your PayPal account to purchase raffle tickets on a great scale airplane the Tiger Moth ready to fly built by a very experienced modeler. Win it Saturday evening at the NASA banquet and fly it Sunday after the Nationals. If you don't have a PayPal account, e-mail me and I will send you the tickets. Send a check made out to NASA for \$5.00/1 chance, \$10.00/3 chances, or \$20.00/ 6 chances (the

best deal). We need your help! Plan on attending and taking the Moth home with you.

There are a couple of other contests coming up. The Mint Julep at it's new site the Ohio River View Flyers site. It is sponsored by the Southern Indiana R/C Modelers, and John Crase is the CD.

The AMA Nationals at Muncie Indiana, will be held July 12-14 at the AMA flying site. Jim Martin is the event director. Come out and support NASA as you can fly or volunteer. Jim can use the help!

The First Annual Columbus Scale Classic will be held August 17-18, at the WMAA flying site in Lewis Center, Ohio (Alum Creek State Park). Come out and enjoy a 900' golf course runway with unlimited over-fly area. If you show up, I am buying everyone dinner Saturday evening at the Monster Hanger. The event fee will be \$30.00 with a \$5.00 discount for pre-registration before August 10th. Second entries are \$10.00/class. It is AMA sanctioned and a Scale Masters qualifier. For more info, motels, etc. visit www.wmaa-wags.org. Come on over to Columbus and have some fun! August 17th is National Model Aviation Day. Celebrate with us at a scale contest!

That's all for now support NASA and our events.

MIKE BARBEE
mabarbee@aol.com

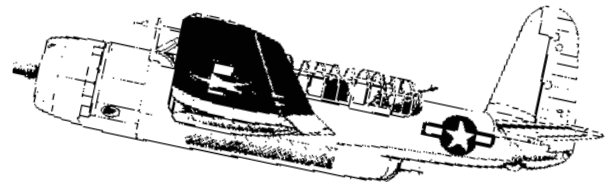

Scale Event Calendar

MINT JULEP

June 7-9, 2013 - Rosewood Indiana
<http://www.sircm.com/Mint-Julep.html>

AMA NATIONAL SCALE CHAMPIONSHIPS

July 12-14, 2013 - Muncie, Indiana
<http://www.modelaircraft.org/events/nats.aspx>

EAA AIRVENTURE

July 29 - August 4, 2012 - Oshkosh, Wisconsin
<http://www.airventure.org/>

COLUMBUS SCALE CLASSIC

Aug 17-18, 2012 - Westerville, Ohio
<http://www.nasascale.org/pdfs/CScaleC2013.pdf>

AERO-PAC

SCALE DOCUMENTATION FOR THE DIGITAL AGE.



- Each Aero-Pac is devoted to a single airframe.
- The documentation comes on a cd-rom and is viewable in any modern Mac/Windows web browser.
- Includes walk-around, exterior & interior details, enhanced close-ups, and 3-views and more!

How Do THEY WORK?

CLICK HERE TO FIND OUT.

- All wording (n-numbers, nomenclature, etc.) are shot close-up and head-on for easier duplication.
- Compatible with Mac and Windows computer systems.

CLICK HERE TO SEE ALL OF OUR AERO-PACS ONLINE AT AIRBORNE MEDIA.COM

All Aero-Pac's are \$19.95 + \$5.50 s&h for the first, \$1.50 each additional.
(US domestic shipping rate)



Call Toll Free: 888-829-4060
7414 Burton Drive, Liberty Twp, OH 45044

2013 Scale National Championships Bulletin Update 1



2013 RC SCALE NATIONALS - FRIDAY JULY 9TH THROUGH 11TH

LOCATION OF COMPETITION

All outdoor events RC and CL will be static judged at large tent at the National Flying Site, AMA Headquarters. Pick up your contestant badge and information at the AMA National Headquarters building by the pond, then go to the scale nationals tent by the white house for your static judging slot and flight line order. **ALL COMPETITORS MUST REGISTER AT THE STATIC SITE**, no matter what class you are registered in.

All outdoor events RC and CL will be flown at the AMA National Flying Site on Saturday and Sunday till completion.

PARTICIPATION

Anyone who is an AMA member can compete at the AMA National Championships. To compete in the Scale National Championships you only need to have a model of a full scale aircraft. There are classes for anything from Fun Scale (where you can actually buy your model) or where most of the models are either scratch built or built from plans. You must have successfully flown your entry before and follow the AMA Safety Code.

Notice: This year NASA will crown both a Scale Champion in RC Scale as well as CL Scale at the awards ceremony on Sunday. This has been introduced by NASA and special significant awards will presented to these two Champions. Classes eligible for these awards include:

<u>RC Scale</u>	<u>CL Scale</u>
Sport Scale Designer	Sport Scale
Sport Scale Expert	

There will be only one Champion in RC Scale and one Champion in CL Scale. The selection process is simple, the contestant who has the highest score overall, including all 4 flights + the static score wins.

<u>RC Scale All Classes</u>	<u>CL Scale All Classes</u>
#520 Fun Scale Open	#520 Fun Scale
#511 Sportsman	#510 FAI F4B Scale
#512 Expert Sport Scale	#521 Profile Scale
#515 Designer Scale	#527 Team Scale
#522 Team Scale	#526 Fun Scale CL
#523 Open Scale	

COMPETITION RULES

All AMA Rules & Regulations General and Scale will used. If any modifications are made or "local rules" are used you will find them here in the Scale National Bulletins. Current AMA safety rules apply, please check the website for the latest copy of these rules.

AMA LICENSES

All competitors must have their AMA Membership Card with them at the competition sites at all times. Your AMA card must be shown to register this also applies to anyone from outside the country who competes, for foreign competitors please check with AMA Competition Department for the latest updates.

7. COMPETITORS ENTRY FORM

Each competitor must have filled out your Entry Form as well as which class you intend to compete in before static judging begins.

Rates: 1st entry \$70.00 2nd entry \$25
NO ENTRIES AFTER JULY 10TH

FREQUENCIES

All of the aircraft frequencies available to aeromodeling are available to us this year as we are preceded by the Free Flight Nationals. Scale classes for the Free Flight Nationals are held on Thursday before competition starts for us. In RC events, everyone is encouraged to fly RC on 2.4.

HOTEL ACCOMMODATIONS

The official Host NASA Hotel this year will be the:

Super 8 Motel (765)-286-4333, West Foxridge Lane, Muncie
For special AMA rates be sure to mention this is for the AMA National Scale Championships. Also call the hotel in Muncie, not the national

1-800 number to receive the AMA discount, you have to ask for it!

OTHER ACCOMMODATIONS:

Comfort Inn (765)-587-0294
Days Inn(765)-288-2311, N. Everbrook, Muncie
Fairfield Inn (765)-282-6666, 4011 Bethel St. Muncie, IN
Holiday Inn Express, (765)-289-4678, 4201 W. Bethel Ave. Muncie.
Best Western, (765)-282-0600, 3011 W. Bethel Ave. Muncie.
Days Inn, (765)-288-2311, 3509 N. Everbrook, Muncie.
Lees Inn, (765)-282-7557, 3302 N. Everbrook Ln. Muncie
Signature Inn, (765)-284-4200, 3400 Chadam Lane, Muncie.

Camping- is available on a first come first served basis for both RVs as well as tent campers. There are a limited number of hookups. Shower facilities as well as a dump station are on the AMA National flying site. The RV sites fill up fast, so be early! Free Flight will be there during the week preceding our events.

CONTINUED ON NEXT PAGE...

PRACTICE SITES

Practice is available to outdoor RC and CL scale models. Practice is usually flown after static judging on Friday (evening), before official flights on Saturday begin. Outdoor Free Flight must be finished before we set up.

OFFICIAL ENTRY

Official AMA entry forms should be received by July 10th 2013. AMA Entry forms have to be sent to AMA Headquarters Attn: Yolanda Jones AMA National Championships, 5161 E. Memorial Dr. Muncie, IN 47302 These can also be faxed to (765)- 289-4248 (with credit card payment)

SCHEDULE ALL EVENTS

Friday July 12th

- Static Judging under the tent!
All Scale Static Judging near the Scale Nationals Headquarters (white house) - National Flying Site
- 8:00am to completion.
All outdoor Scale static for fixed wing powered RC and CL classes includes Fun Scale & Profile Scale.
- 5:30pm
Practice and fun-fly at the AMA National Flying Site both the RC as well as the CL sites for the Nationals will be open for scale modelers.

Saturday July 13th

- Scale RC and CL Outdoor Flight Competition AMA National Flying Site
- 8:00am
Fly rounds 1 and 2 with a break for lunch to bring your model out on the runway for spectators to take a close look at.
- 5:00pm or after flying finishes
NASA's Nationals Banquet at the Claude McCullough Building for everyone. Great time for all! Entertainment included Adults \$15.00 Children under 12 years \$5

Sunday July 14th

- Scale RC and CL Outdoor Flight Competition AMA National Flying Site
- 8:00am
Fly rounds 3 and 4 with a break for lunch
- Awards ceremony following the conclusion of all competition.

This Scale Nationals bulletin was prepared by Stan Alexander. We only have space here to print just a portion of the bulletin. To read the entire bulletin, please click here to view it on the NASA web site.

For complete information on this year's Nationals, as well as up-to-date news, please click here.

NASA NEWS AND INFORMATION ON THE INTERNET

If you have internet access, you owe it to yourself to visit NASA's web site - www.nasascale.org. The NASA site was designed from the start to be the only place you need to go to find out everything that's happening in the world of scale aeromodeling - whether it's here on the National front, or on the International front - the domain of the FAI.

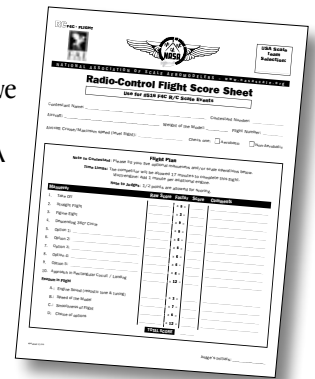

COMPETITION DOCS/FORMS

This is one of the more exciting features of the web-site. We have all the competition forms and documents for scale competition online in pdf form. Not only are the documents up-to-date, but we now have two versions of each.

One is the regular pdf that we invite contest directors to download and printout for use in their contests.

The second (and more exciting) version of the form is the "intelligent" form. Using this version and an up-to-date version of Adobe's Acrobat Reader, you can fill out all your information using your computer, then pre-print copies to take to your next scale event: information about yourself, your plane and your maneuvers/options. All AMA rule book maneuvers/options (as spelled out in the current AMA rule book) can be selected from pull-down menus; right on the .pdf. Imagine not having to spend time at your next contest filling out forms!

When one engine fails on a twin-engine airplane you always have enough power left to get you to the scene of the crash.



NATS - This Just in...

I checked with AMA and anyone arriving early with campers, motor homes, trailers, etc. can still park at the flying site camp/shower parking lot.

They can not set-up any tents or dining flies at the runway until after 3pm Friday.

Free Flight has the whole AMA facility from 8 -5 Monday thru Thursday and 8-3 on Friday (July 8 - 12).

Please refrain from parking in the parking area immediately behind the runway during the Free Flight times.

No R/C flying can be done during those times but open flying starts after 5pm each day.

JIM MARTIN
Jim.Martin@faa.gov

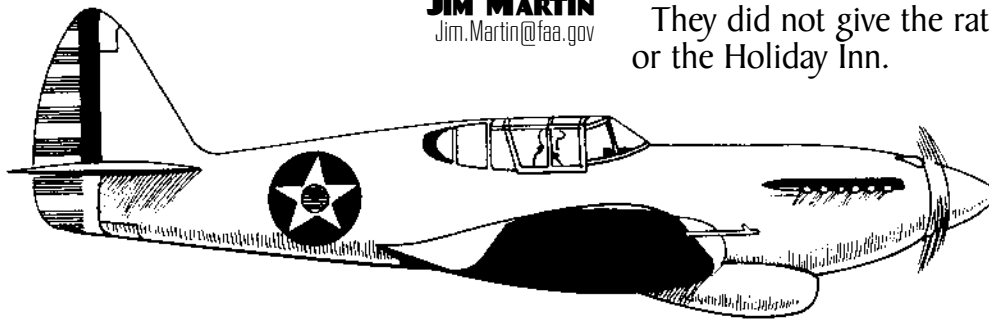

Attention All AMA Members:

When contacting the hotels at Muncie for NATS room reservations, tell them you're with the AMA to get the AMA rate. All hotels except the Fairfield have special AMA rates (prices vary plus tax).

Baymont Inn (old Signature) - \$66,

Lee's Inn - \$59,

Comfort Inn - \$75,

Days Inn - \$54 (must show AMA card),

Super 8 - \$55,

Fairfield - \$95.

They did not give the rates for the Hampton Inn or the Holiday Inn.

JIM MARTIN
Jim.Martin@faa.gov

SCALE AVIATOR™ INTERNATIONAL

The RC Scale Aviation Magazine in an Online Format

Visit the website and Review the FREE 25 page sample edition. See all the features too. Its Digital!



6 scale packed issues per year
One Year Subscription \$26.95 USD
PayPal - Credit Cards

View on your PC or MAC with dynamic page turns, zoom, archive to your files, email, print or save as a PDF on your desktop.

Auto Formats for Ipad & Smart Phones. No iTunes App Required!

www.scaleaviatorint.com

12 Inches to the Foot

BAE Hawks and Thunderbolts dominated the numbers at Top Gun this year more than any other type present. The Hawk kits are very large and fly well (as one pilot described to me) like a trainer. While the Thunderbolts, we are seeing in 1/4 scale now with Moki 250 radial engines mounted to the nose. It's interesting to see who the size has increased in the past 10 years. The change is huge. Modeling keeps changing too. We see more and more fiberglass/foam/carbon fiber kits now and less balsa and stick kits. There were several civilian types there including a beautiful Stinson SR9 in American Airline colors.



"Does this model have an N number for a Model Y Senior Sportster?". Naw, it can't be that they could have made a mistake that bad, could they? Yes they did.

Now the internet has picked up on this mislabeled Gee Bee E, and its all over that this is a true Gee Bee. The Senior Sportster had a larger wingspan and a 9 cylinder radial engine. Where the little E model had a 7 cylinder Warner engine (as well as several others). The only aircraft that I'm aware of that featured the Filaloola Bird (a comic strip character of the day) was the first Model Y Senior Sportster. Its not rocket science, just a little search and you have an accurate model. Not a Sunday fun flyer.

Mike and Barb Barbee were at Top Gun this year and Barb had her jewelry booth set up and was selling NASA Raffle tickets as well for us! I really appreciate that Barb. Mike took 1st Place in Expert with his new Beech T-34B, which was one of the largest planes to attend the contest.



The kicker is these companies who just decide on a whim to paint a scale model any color they want or apply any markings they want to, do themselves and all modelers a disservice. It also hurts the companies, as well as their history. Now I'll get off my soap box.

For more information about the Gee Bees and the Granville Brothers who built them contact a book store and purchase "Gee Bee The REAL Story of the Granville Brothers and Their Marvelous Airplanes" by Henry Haffke. Click on this link to see this book online.

I missed the Mint Julep this May in Rough River Kentucky. Some modelers I've talked to are thinking about just all meeting up there in May and flying if they will let us, which I really don't think they will with the FAA and Parks Service. But I do miss that place and all our friends who traveled there each spring. It was the first contest for most of us, a lead up to the Nationals.

There are several replicas of the Gee Bees around the country including a Model Z Super Sportster, Model Y Senior Sportster, Model E, as well as the R-2 Super Sportster.

AN AWF IS AN AWF IS A DOG SOMETIMES.

You can say some manufacturers really work hard to not only make a model that flies well when it's a scale model, but they also try to make sure that the model they construct for us is an actual airplane! I.E. that a full scale aircraft existed or does exist like they one they are modeling.

I've seen several useless goofs lately on models where the N number didn't match the full scale and for entering Fun Scale that pretty much makes the model once again, useless. But even worse, some have been coming out with paint schemes that never existed. It is not that difficult guys! Come on!

Recently, a company came out with a model of a Gee Bee Model E Sportster. Great! Good! I'm always a sucker for a good Gee Bee model. But at looking at the model and then thinking

Fair Skies & Tail Winds and remember, "Work to live, don't live to work!"

STAN ALEXANDER
onawing4602@att.net



Bellanca 28-92 Trimotor 3-View

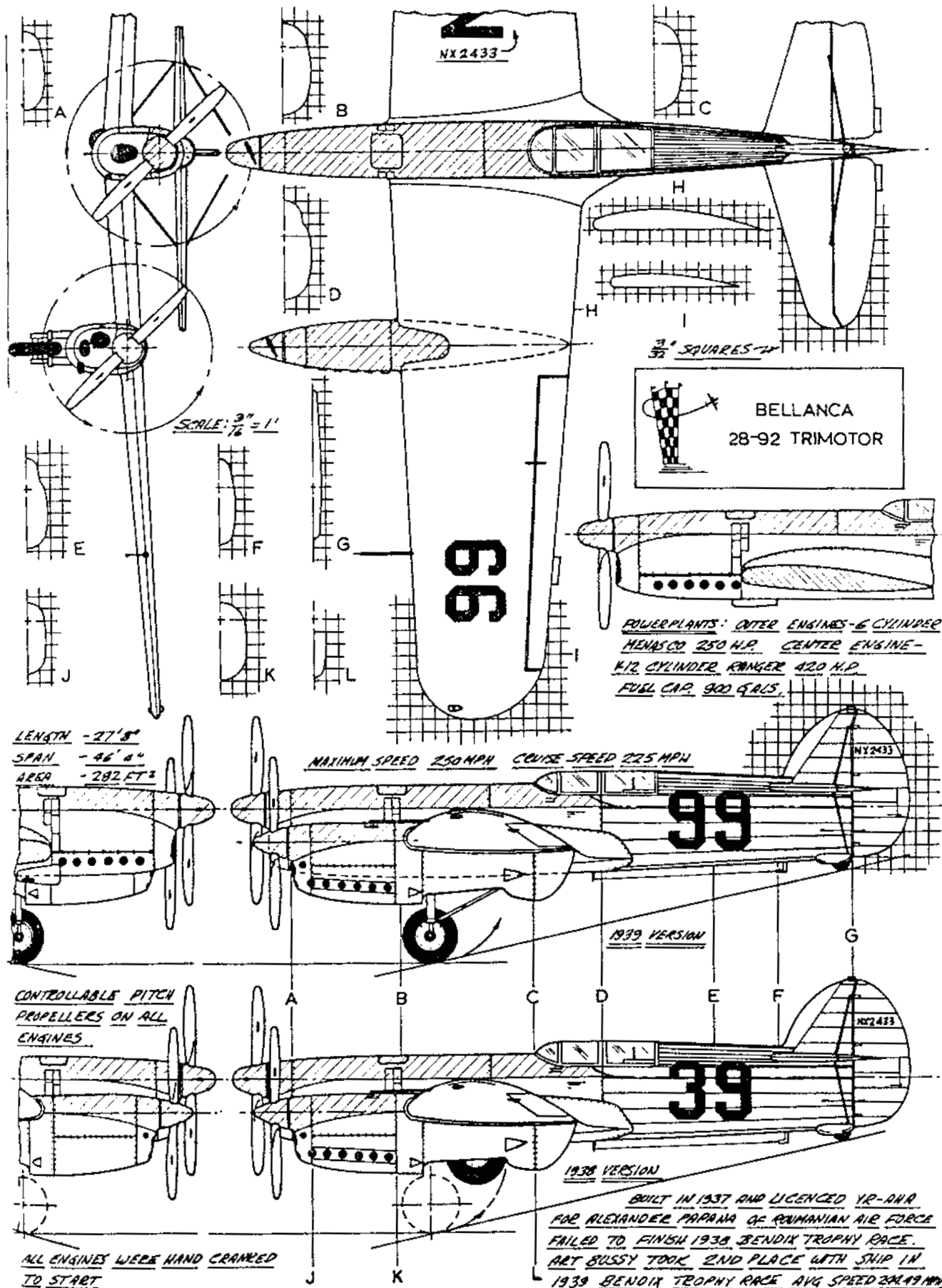

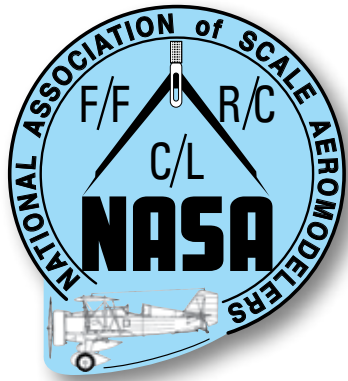

IN THIS ISSUE:

- **RENEW YOUR NASA MEMBERSHIP TODAY!**
- **THE LATEST IN SCALE NEWS! • BELLANCA 26-92 TRIMOTOR 3-VIEW**

Join NASA Today! Complete the following application (please print) and mail it to
Bob Lirette, Secretary/Treasurer NASA, W162 N9440 Blackfoot Dr., Menomonee Falls, WI 53051

Membership dues are \$20.00 yearly (newsletters sent to foreign members sent by e-mail,
or \$25.00 foreign with newsletters set by post.)

Make checks or money orders payable to: **National Association of Scale Aeromodelers.**

Name: _____ New Renewal Address Change

Address: _____

City: _____ State: _____ Zip: _____ Country: _____

Tel: _____ - _____ - _____ E-mail: _____ AMA # _____ NASA # _____

Area of Interest: Free Flight Control Line Radio Control Giant Sailplane Electric

CHECK HERE if you do NOT want your name and address included in a directory to be distributed to NASA members. NASA will not sell this directory to anyone.

REPLICAS

REPLICA EDITOR

MARK LANTERMAN

7414 Burton Drive
Liberty Township, Ohio 45044