

REPLICA

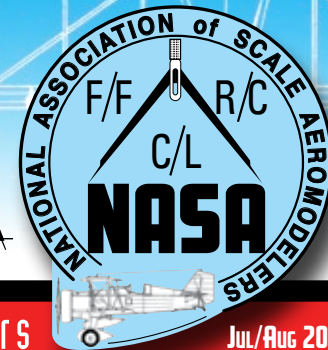

Newsletter of the National Association of Scale Aeromodelers

Jul/Aug 2012

Editor's Notes

Well, since our President hasn't sent anything in for this issue, I'm going to take over his space and cover a couple of topics.

First, I want to thank all of you for being members of NASA. We all have a love and passion for our scale models, and I believe that we all have a lot to learn from each other.

Having just returned from competing in the R/C side of the Nats, I wanted to bring to light a rumor that was swirling around on the Control-Line side, and that was an attempt to drum up support to split C/L from NASA. I won't even pretend to know the details, but I do know this. There just aren't that many scale modelers these days. Our numbers are dwindling and because of this, **WE ARE MUCH STRONGER AS A UNITED GROUP!**

Some may think that C/L and even F/F don't receive the attention that the R/C portion of NASA does. Maybe there's some truth to this because of the disproportionate number of R/C modelers in NASA. However, we need input from F/F and C/L. Personally, I'd love to see our officers represent all 3 phases of our membership, not just R/C. I welcome any articles and event coverage for the Replica and will do my best to make sure that each issue (and our website) has something for ALL of us!

In closing, I want to thank all the contest directors, judges, volunteers and sponsors who helped NASA with this year's Nats. Let's do it again next year - bigger and better than ever!



This is me with my new caller this year; my son Spencer

MARK LANTERMAN
mark@airbornemedia.com

2012 AMA NATS Sponsors

We'd like to offer a huge THANK YOU to all of the sponsors who helped us with this year's Nationals.

DIAMOND SPONSORS

Balsa USA
Baskets By: Shannon
Great Planes Dist.

Horizon Hobby
Robert's Aviation

GOLD SPONSORS

Airborne Media
Ali Industries, Inc.
Bob Smith Industries
Futaba
Global Hobby Distributors
JZ Products
Leisure RC Models
MGA Enterprises

Model Airplane News
Model Expo Inc.
Steve & Shannon Ort
Wendell Hostetler's Plans
Williams Brothers Model Prod.

SILVER SPONSORS

Aeroworks
Aircraft Spruce & Specialty
APC Landing Products
Excel Hobby & Blades
J&L Power Products
Nick Zirola Plans

BRONZE SPONSORS

Micro Fasteners
Northeast Screen Graphics
RAM
Tower Hobbies
Zona Tool Co.

NASA OFFICERS

PRESIDENT

MIKE BARBEE
3903 Whispering Creek Lane
Delaware, Ohio 43015
740-362-5504
mabarbee@aol.com

VICE PRESIDENT

PAUL CAIN
1906 Center Street
New Albany, Indiana 47150
812-945-3103
c103iflyrc@att.net

SECRETARY/TREASURER

BOB LIRETTE
W162 N9440 Blackfoot Drive
Menomonee Falls, Wisconsin 53051
262-251-0804
blirette@sbcglobal.net

REPLICA EDITOR/ NASA WEBMASTER

MARK LANTERMAN
7414 Burton Drive
Liberty Township, Ohio 45044
513-755-7494
mark@airbornemedia.com

Scale Event Calendar

DAWN PATROL

August 10-12, 2012 - Umpqua, Oregon
<http://www.nasascale.org/pdfs/2012-dawn-patrol.pdf>

THE FCM AT AMA

August 25-26, 2012 - Muncie, Indiana
<http://www.nasascale.org/pdfs/fcm2012%20flyer.pdf>

1/8 AIRFORCE FALL SCALE FLY-IN

October 20-21, 2012 - Utery Park, Arizona
<http://www.nasascale.org/pdfs/oeaf2012.pdf>

FOR ADDITIONAL EVENTS, VISIT
[HTTP://WWW.NASASCALE.ORG/CALENDAR.HTM](http://WWW.NASASCALE.ORG/CALENDAR.HTM)

AERO-PAC

SCALE DOCUMENTATION FOR THE DIGITAL AGE.



- Each Aero-Pac is devoted to a single airframe.
- The documentation comes on a cd-rom and is viewable in any modern Mac/Windows web browser.
- Includes walk-around, exterior & interior details, enhanced close-ups, and 3-views and more!

HOW DO THEY WORK?
[CLICK HERE TO FIND OUT.](#)

- All wording (n-numbers, nomenclature, etc.) are shot close-up and head-on for easier duplication.
- Compatible with Mac and Windows computer systems.

CLICK HERE TO SEE ALL OF OUR AERO-PACS ONLINE AT AIRBORNEMEDIA.COM

All Aero-Pac's are \$15.95 + \$5.50 s&h for the first, \$1.50 each additional.



Call Toll Free: 888-829-4060
 7414 Burton Drive, Liberty Twp, OH 45044

Renew your NASA membership today! fill out the form on the back page and mail it in today!

Scale Terminology:

Wing: a device that, due to its airfoil, allows air to flow faster over the top, thereby giving you the opportunity to pour excess funding into the resulting low-pressure area.

Painting film Coverings

The below is a discovery by a friend of mine in the Pylon world. I have not tried this myself but he is a credible builder and should work pretty good to personalize any ARF. If you try this product as described I would like to hear about the result.

TOM SCOTT

tscott1@cinci.rr.com

For those of you who want to use trim a monokoted ARF or any other film covered plane with paint, your options have been very limited until now.

You can now go to Ace Hardware (and other places) for this great new paint from Rustoleum in a spray can. This version is called "Painters Touch" It sticks to plastic aggressively. On monokote its unbelievable! I swear you don't have to prep the film in any way. It comes in a variety of colors including some satins or flats. Prep and masking off for trim is a breeze. Can handle in a couple hours and mask over it in six. Using any of the adhesive tapes in my box, I have not been able to pull up any paint that was on the film. Its like a miracle. \$3.99 a can.

The spray head is remarkable. It allows you to spray in any position and I've never seen one clog. The spray pattern is really nice. The paint has a lot of solids in it so it covers very quickly. It also appears to be fuel proof. Jerry Small and I both tested against 15% fuel. I checked the primer as well and we never saw any hint of a issue. Granted, this is not official.

They have several colors of primer. I started using the product because I love the primer. Its an easy sanding primer that builds and fills well. I discovered it stuck to monokote by accident when some overspray got onto one of my planes. I was able to clean off the overspray but it was an impressive adhesion. If you use their primer and your finish is smooth, you can spray the color within two hours of spraying the primer. It works great, the paint flattens out really nice without a lot of buildup. The edges of the paint lines are hardly noticeable because you are not putting down very much paint. This stuff is WAY better than the TopFlite paint. By the way, do not use this stuff with the TopFlite paint. I tried and it was a terrible outcome.

CHUCK ANDERSON, OKC

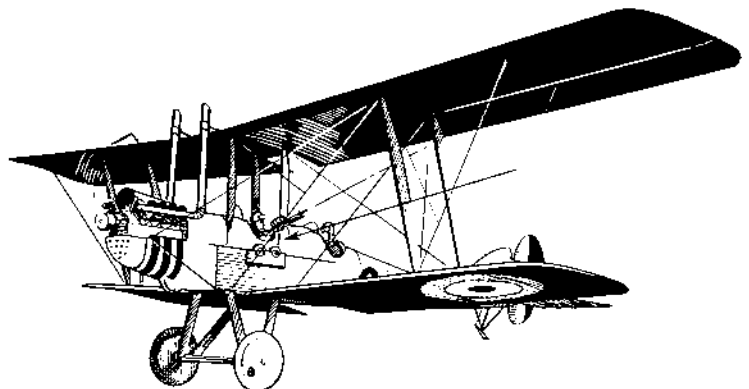

NASA Member Projects Online

Take a few minutes to send us a bit of information on your latest project. We're featuring NASA member's scale projects online in our blog. It's new, and to get an idea of what we're looking for, visit the NASA site and click on the Members Projects link at the top of any page. Or you can visit this section at the following address:

<http://nasascale.wordpress.com>



All we need is a paragraph or two about your project. Include the name of the model, the type of power, radio brand, and details of any special features you're incorporated. Attach nice, high-res photos and we'll get it online!

To submit your projects, e-mail the info to: info@nasascale.org

2012 FAC NATS Photos

We received several photos from the 2012 FAC NATS from Mike Welshans.

Unfortunately, we don't have space to print them, however you can view all of them by visiting NASA's online photo galleries at: www.nasascale.org/galleries



Thanks to Mike for sending in these photos, and we welcome photos from any of our members. If you're at an event, a fly-in, a contest, or any other event, snap some photos and send them to us.

For details, contact our webmaster, Mark Lanterman. You can contact him here: mark@airbornemedia.com

Mankind has a perfect record in aviation: We've never left one up there



SCALE AVIATOR INTERNATIONAL

The RC Scale Aviation Magazine in an Online Format

Visit the website and Review the FREE 25 page sample edition. See all the features too. Its Digital!



6 scale packed issues per year
One Year Subscription \$26.95 USD
PayPal - Credit Cards

View on your PC or MAC with dynamic page turns, zoom, archive to your files, email, print or save as a PDF on your desktop. Auto Formats for iPad & Smart Phones. No iTunes App Required!

www.scaleaviatorint.com

2012 Scale NATS Scrapbook



View more NATS pics online at NASA's online photo galleries: www.nasascale.org/galleries

2012 Scale NATS Scores

We've gathered the official placings for all of the Control-Line and Radio-Control events at this year's Scale Nationals.

Our sincere congratulations to all of our new National Champions and everyone else who competed against them.

We hope to see you all again next year and if you've never competed, please think about joining us. It's a great event!



R/C TEAM SCALE

- | | | | |
|----|-----------------------|-------|---------|
| 1. | Dale and Jeremy Arvin | SNJ-6 | 191.375 |
|----|-----------------------|-------|---------|

R/C DESIGNER SCALE

- | | | | |
|----|-------------|----------------|---------|
| 1. | Hal Parenti | Ryan Fireball | 191.125 |
| 2. | Bob Patton | T-34B | 190.375 |
| 3. | Al Kretz | Dornier Do 23G | 142.375 |

R/C SPORT SCALE EXPERT

- | | | | |
|----|--------------|----------------|---------|
| 1. | Mike Barbee | NA T-34C | 195.750 |
| 2. | Dave Pinegar | Piper Arrow II | 193.750 |
| 3. | Gary Parenti | Beta Minor | 185.50 |

R/C SPORT SCALE SPORTSMAN

- | | | | |
|----|-------------|-------------------|---------|
| 1. | Frank Mintz | Champion Citabria | 155.375 |
| 2. | Cabe Renero | Ryan STA | 99.250 |

R/C FUN SCALE NOVICE

- | | | | |
|----|-----------------|------------|-------|
| 1. | Steve Ort Jr. | Van's RV 4 | 88.00 |
| 2. | Evan Gaston | Skyfarer | 84.63 |
| 3. | Glenn Learnahan | J-3 Cub | 84.50 |

R/C FUN SCALE ADVANCED

- | | | | |
|----|--------------|--------------|--------|
| 1. | Terry Nitsch | NA F-86 | 101.38 |
| 2. | Mike Barbee | Piper Cub | 100.50 |
| 3. | Jeremy Arvin | P-51 Mustang | 100.50 |

R/C FUN SCALE AEROBATIC

- | | | | |
|----|----------------|----------------|---------|
| 1. | Dave Pinegar | P-51 | 100.875 |
| 2. | Mark Lanterman | Tucano | 98.375 |
| 3. | Ron Hemphill | Cessna Aerobat | 92.875 |

R/C AMA OPEN/ADVANCED

- | | | | |
|----|----------------|----------------|---------|
| 1. | Steve Ort Sr. | Super Stearman | 156.375 |
| 2. | Jeff Pike | Twin Otter | 153.500 |
| 3. | Earl Dever Sr. | Pilatus Porter | 151.875 |

NASA FLIGHT ACHIEVEMENT AWARD

Evan Gaston (Award Hangar 9 D.H. Tiger Moth)

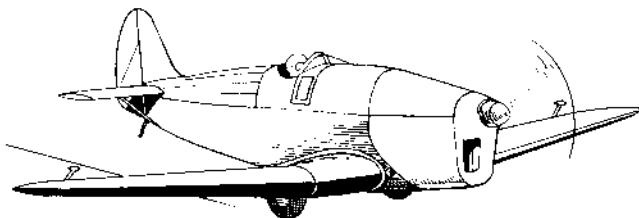

509 C/L SPORT SCALE

- | | | |
|---|---|---------------------|
| 1 | O | John G Brodak |
| 2 | O | Richard D Schneider |
| 3 | O | Edward V Mason |

509JS C/L SPORT SCALE

- | | | |
|---|---|---------------|
| 1 | S | Jason C Bauer |
|---|---|---------------|

510 F4B C/L SCALE

- | | | |
|---|---|---------------------|
| 1 | O | Allen L Goff |
| 2 | O | Richard D Schneider |
| 3 | O | Charles Bauer |

521 C/L PROFILE SCALE

- | | | |
|---|----|-----------------|
| 1 | O | John O Wright |
| 2 | Fo | Chris Brownhill |
| 3 | O | William R Avera |

521JS C/L PROFILE SCALE

- | | | |
|---|---|---------------|
| 1 | S | Jason C Bauer |
|---|---|---------------|

526 C/L FUN SCALE

- | | | |
|---|----|------------------|
| 1 | O | William R Avera |
| 2 | Fo | Chris Brownhill |
| 3 | O | Kenny Stevens Jr |

527 C/L TEAM SCALE

- | | | |
|---|---|----------------------|
| 1 | O | Kenny Stevens Jr |
| 1 | O | Kenneth E Stevens Sr |
| 2 | O | Jeffrey J Jensen |
| 2 | O | James J Jensen |
| 3 | O | William R Avera |
| 3 | O | Edward V Mason |

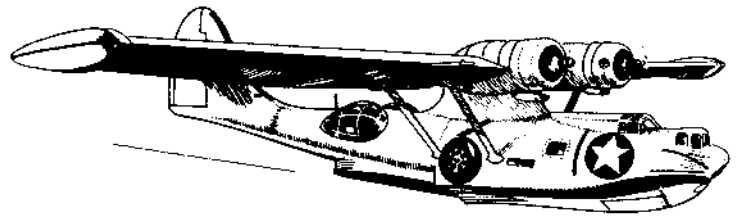

12 Inches to the Foot

This year's Nationals (and I'll always call it that) was a great event in many ways. On the R/C side of things Jim Martin and Shannon Ort as well as NASA VP Paul Cain ran a great event. The contestant numbers were still below expectations this year. Some say gas, some say jobs but I'd like to point out that the entry fee for your first Nationals entry was again \$70. By international standards that's very low. By standards here in the USA, that is one of the most expensive contests you can attend. At a Scale World Championship the entry fee is about \$470 - euro not dollars. Of course that doesn't include food, hotel, travel and other stuff tacked on.



The thing I don't understand is that the Free Flight Nationals has such low entry fees, and this is from AMA. In talking to a friend who was going to the FF Nationals later after the Scale event, he stated that he was entering 5 events and the total cost was \$45. Where is the disconnect here??

Also NASA, to help defer judges costs in the past, always used the 2nd and 3rd entry fees of \$20 each to offset judges expenses. Now AMA also takes part of that. When did that happen? And better yet, why?

The banquet we had on Saturday night was a great time but there were many of our friends on the C/L Scale events didn't attend, all I can say is guys and gals you missed a great time, and I wish you had also been there. Ah, we should have taken that opportunity and had a NASA membership meeting with the board meeting held afterward, I guess.

But weather you fly Free Flight, Control Line or Radio Control Scale, we all have to remember that we are all in this together. Scale is too small a community to splinter into oblivion which I believe some would enjoy sitting back and watching happen while the whole thing falls apart. Yes, R/C scale gets the most attention from the press, as many more are flying this event, but the C/L entries at the Nationals this year were up and I just wish we could have had the F/F Scale events there at the same time also as we did in the past.

Having other modelers there from other events judging static and in some cases flight is a great help to the organization as well as the modelers themselves. As we all learn from each other and continue to grow in this great hobby.

My time was spent working on the R/C side of the Nats News which is online from AMA and also on the NASA website. Ted Kraver took care of the C/L Scale events as I was trying to fly in R/C Fun Scale.

Good thing I didn't have symbols at my knees I guess while I was flying or the judges wouldn't have heard a thing I said as Mark Lanterman tried to make sure I stayed in this country and put in the maneuvers required for a flight. Don't know why but I was actually more nervous at the Nationals than at the Mint Julep, but I was.

It was sad to see several models lost in the competition due

to that cross wind coming from the south all day Saturday. The wind would get under a wing and plop or smash or crash some went. Always remember in high wind keep the speed UP! The heck with scale speed, save that model!

There are a lot of other Nationals stories I have including the one about the 9 year old who flew in R/C Fun Scale Novice. He came in 2nd but that's for another place and time.

Fair Skies & Tail Winds,

STAN ALEXANDER
onawing4602@att.net

www.NasaScale.org

NASA NEWS AND INFORMATION ON THE INTERNET

If you have internet access, you owe it to yourself to visit NASA's web site - www.nasascale.org. The NASA site was designed from the start to be the only place you need to go to find out everything that's happening in the world of scale aeromodelling - whether it's here on the National front, or on the International front - the domain of the FAI.

COMPETITION DOCS/FORMS

This is one of the more exciting features of the web-site. We have all the competition forms and documents for scale competition online in pdf form. Not only are the documents up-to-date, but we now have two versions of each.

One is the regular pdf that we invite contest directors to download and printout for use in their contests.

The second (and more exciting) version of the form is the "intelligent" form. Using this version and an up-to-date version of Adobe's Acrobat Reader, you can fill out all your information using your computer, then pre-print copies to take to your next scale event: information about yourself, your plane and your maneuvers/options. All AMA rule book maneuvers/options (as spelled out in the current AMA rule book) can be selected from pull-down menus; right on the .pdf. Imagine not having to spend time at your next contest filling out forms!

Oh, one more thing - the forms do NOT allow you to fill in your own scores! Sorry - some things are best left up to the judges!

The forms are online now for all Control-Line and RC events - from Fun-Fly up to FAI! Download your forms today!

Comper Swift 3-view

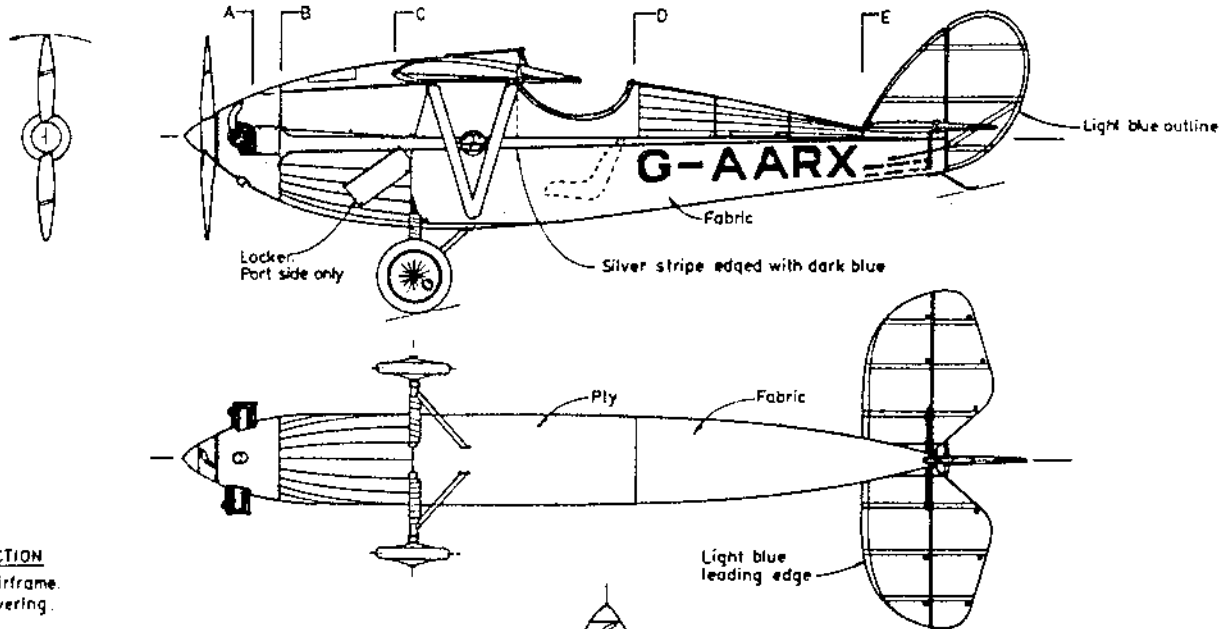

CONSTRUCTION

Wooden airframe.
Fabric covering.

COLOURS

Fuselage, Wheels, All struts.
Light (Cambridge) blue.
Wings & tail.
Silver.
All lettering.
Dark blue.

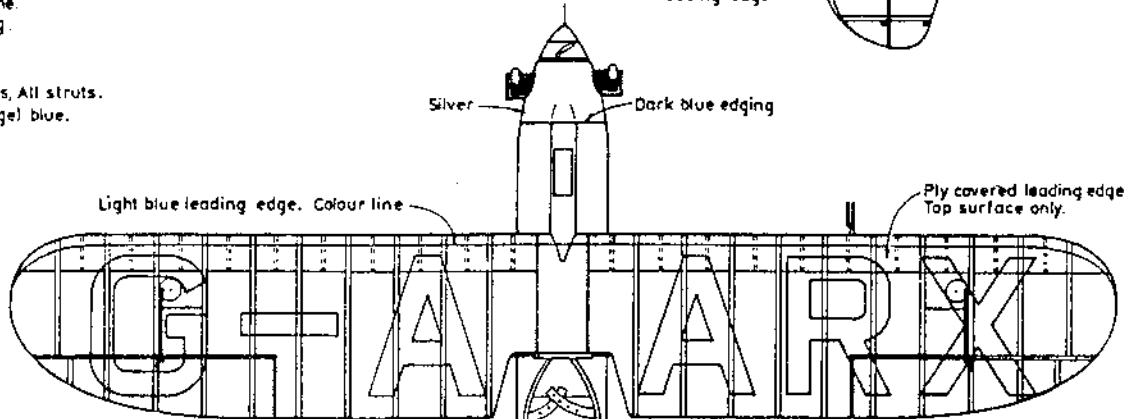

SPECIFICATION

SPAN	24 Ft
LENGTH	18 Ft 4ins
HEIGHT	6 Ft 9ins
ALL UP WEIGHT	500 Lbs
MAX SPEED	105 MPH
ENGINE	35 HP ABC Scorpion
AIRSCREW	Falrey-Reed Twisted metal type

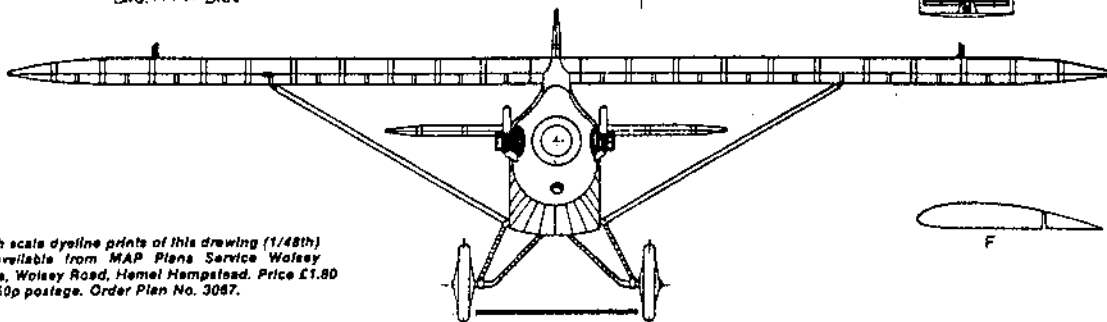
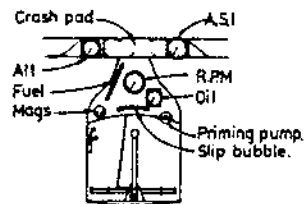
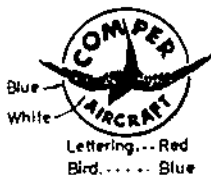
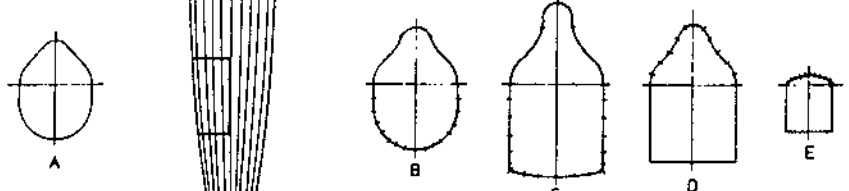

1/24th scale dyeline prints of this drawing (1/48th)
are available from MAP Plans Service Walsley
House, Walsley Road, Hemel Hempstead. Price £1.80
plus 50p postage. Order Plan No. 3087.

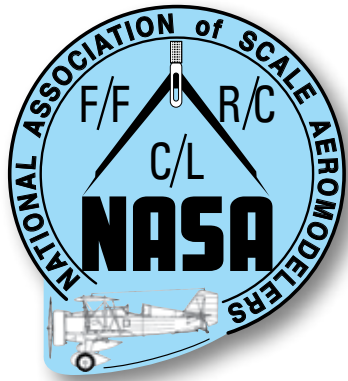

IN THIS ISSUE:

- **2012 SCALE NATIONALS COVERAGE AND RESULTS**
- **THE LATEST IN SCALE NEWS! • COMPER SWIFT 3-VIEW**

Join NASA Today! Complete the following application (please print) and mail it to
Bob Lirette, Secretary/Treasurer NASA, W162 N9440 Blackfoot Dr., Menomonee Falls, WI 53051

Membership dues are \$20.00 yearly (newsletters sent to foreign members sent by e-mail),
or \$25.00 foreign with newsletters set by post.)

Make checks or money orders payable to: **National Association of Scale Aeromodelers.**

Name: _____ New Renewal Address Change

Address: _____

City: _____ State: _____ Zip: _____ Country: _____

Tel: _____ - _____ - _____ E-mail: _____ AMA # _____

Area of Interest: Free Flight Control Line Radio Control Giant Sailplane Electric

CHECK HERE if you do NOT want your name and address included in a directory to be distributed to NASA members. NASA will not sell this directory to anyone.

REPLICAS

REPLICA EDITOR

MARK LANTERMAN

7414 Burton Drive
Liberty Township, Ohio 45044